



ACCESSORY SETUP INSTRUCTION

REAR BUMPER ASSEMBLY -- PN 9AW#-801200-2000

VALID FOR: CFORCE 800XC/ 850XC/ 1000

BEFORE YOU BEGIN: Read and understand the instructions before starting any work. Make sure that all parts are ready and that you have all the tools required for assembly.

NOTE: CFMOTO shall not be liable for any damage caused by incorrect assembly. CFMOTO recommends that all original accessories be assembled by an authorized CFMOTO dealer.

Before assembly, park the vehicle on a flat surface, put the transmission gear into Park (P) and turn off the key switch.

Zhejiang CFMOTO Power Co., Ltd. All rights reserved. Reproduction of this document, even in part, as well as copying of all kinds, is permitted only with the express written permission of the copyright owner.

MEANING OF SYMBOLS

 - Indicates information with more details or tips.

 - Indicates information of warning or danger.

PARTS LIST:

ITEM	PART NAME	PART NUMBER	QTY.	REMARK
1	REAR BUMPER ASSEMBLY	9AW#-801200-2000	1	
2	REAR BUMPER	9AW#-801210-2000	1	
3	POSITIONING BRACKET	9AW#-801201-2000	2	
4	MOUNTING BRACKET, LH	9AW#-801202-2000	1	
5	MOUNTING BRACKET, RH	9AW#-801203-2000	1	
6	PLUG 38	9DS#-801200-6000-20	2	
7	BOLT M8X16	30006-080020870	6	

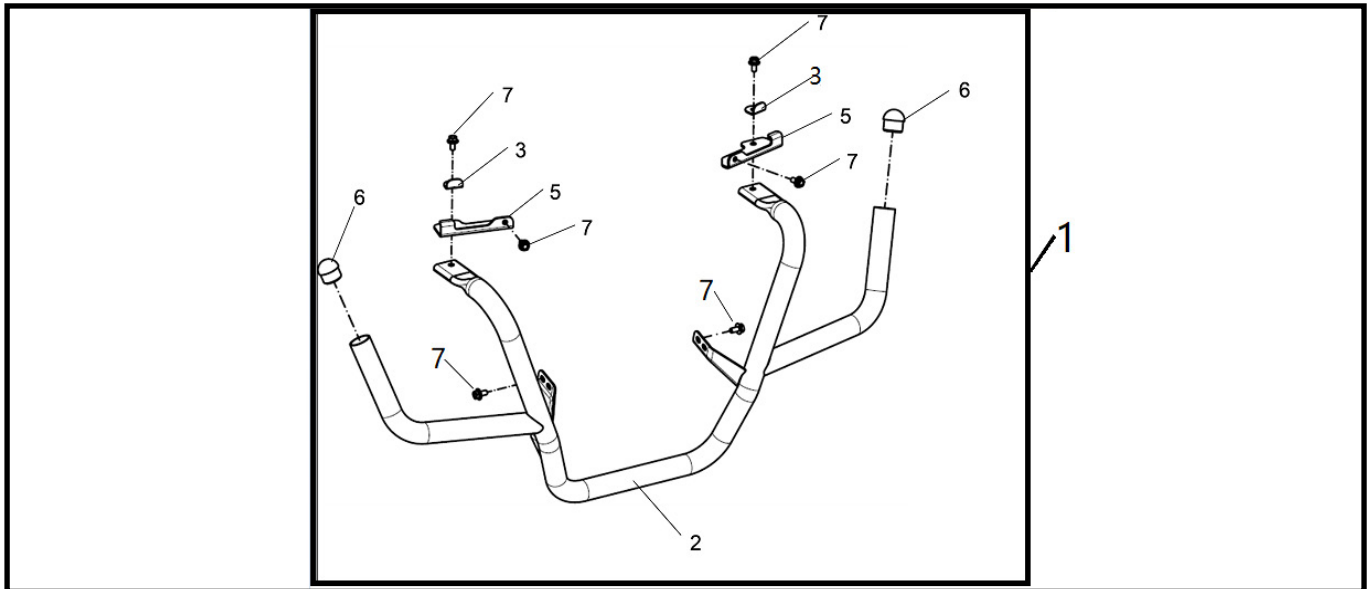

TOOL LIST:

ITEM	DESCRIPTION	QTY.	REMARK
1	13mm SOCKET	1	
2	RUBBER HAMMER	1	
3	PROTECTIVE GLOVES	1	

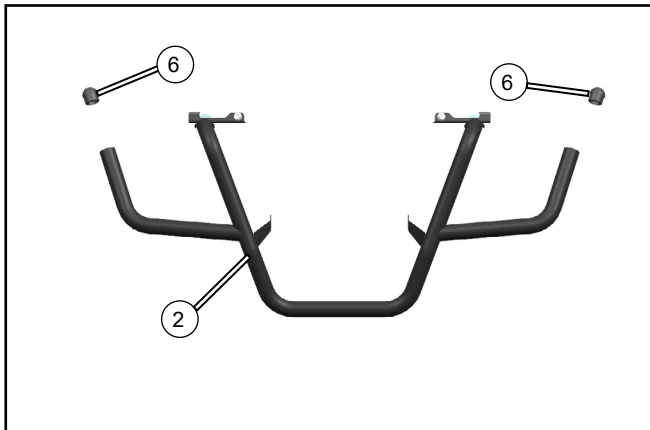
ASSEMBLY and INSTALLATION

// Use a rubber hammer to install the plugs (6) into the rear bumper (2).

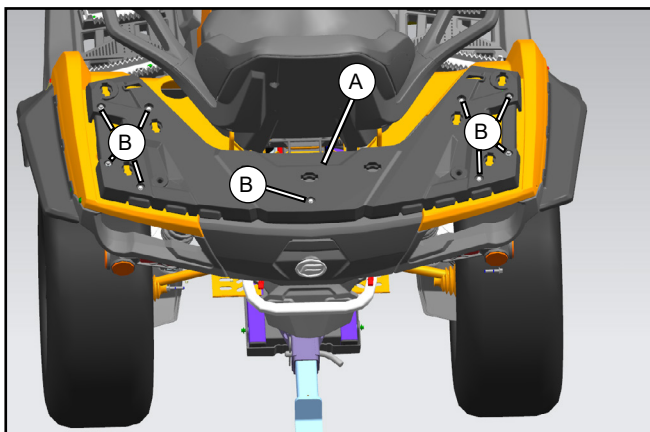

// Remove the bolts (B) and take down the rear rack cover (A).

BOLT	M6x14	8010-000004	6-10N.m
------	-------	-------------	---------

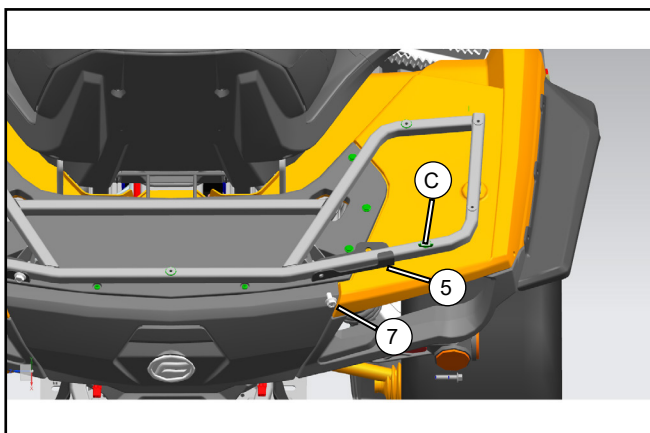

// Install the right mounting bracket (5) to the rear rack (C) with bolts (7).

i The left mounting bracket is installed in the same way.

BOLT	M8x16	30006-080016870	8-16N.m
------	-------	-----------------	---------

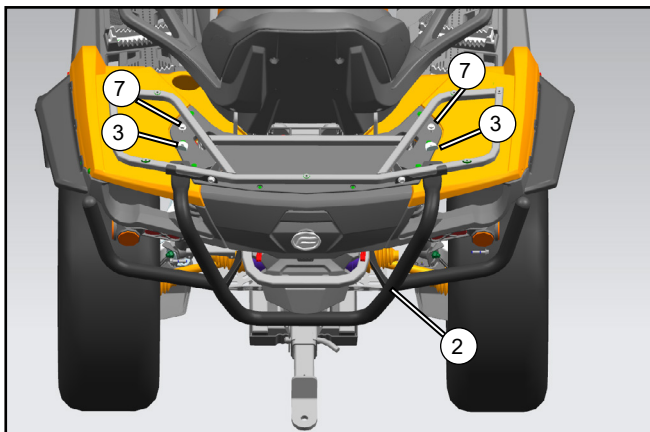

// Place positioning bracket (3) on bolts (7). Align the upper bumper mount (2) to the mounting bracket (4,5) mounting holes, then install the bolts (7). *Do not fully tighten bolts at this time.*

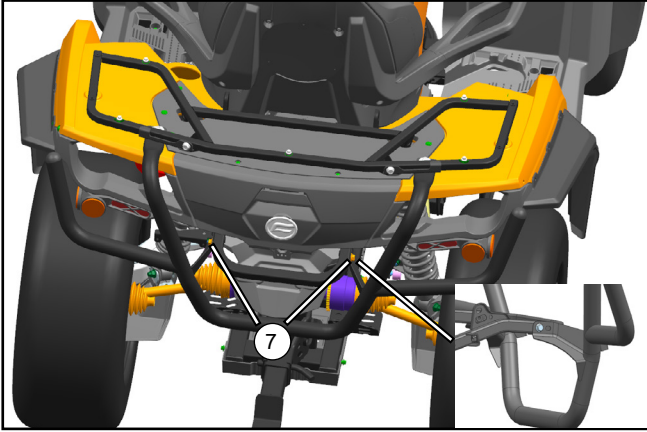
ASSEMBLY and INSTALLATION

- // Align the lower bumper mount to the mounting holes, then install the bolts (7).
- // Tighten all bolts to the specified torque value.

BOLT	M8x16	30006-080016870	8-16N.m
------	-------	-----------------	---------

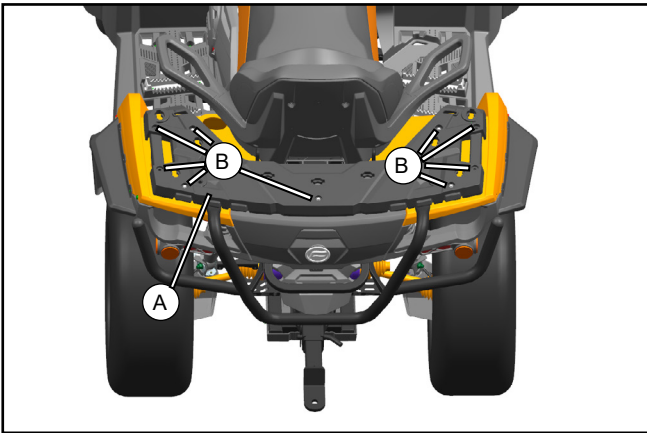

- // Install the rear rack cover (A) with bolts (B).

BOLT	M6x14	8010-000004	6-10N.m
------	-------	-------------	---------