



ACCESSORY SETUP INSTRUCTION

FRONT BUMPER ASSEMBLY -- PN 9AW#-801100-2000

VALID FOR: CFORCE 800XC / 850XC / 1000

BEFORE YOU BEGIN: Read and understand the instructions before starting any work. Make sure that all parts are ready and that you have all the tools required for assembly.

NOTE: CFMOTO shall not be liable for any damage caused by incorrect assembly. CFMOTO recommends that all original accessories be assembled by an authorized CFMOTO dealer.

Before assembly, park the vehicle on a flat surface, put the transmission gear into Park (P) and turn off the key switch.

Zhejiang CFMOTO Power Co., Ltd. All rights reserved. Reproduction of this document, even in part, as well as copying of all kinds, is permitted only with the express written permission of the copyright owner.

MEANING OF SYMBOLS

 - Indicates information with more details or tips.

 - Indicates information of warning or danger.

PARTS LIST:

ITEM	PART NAME	PART NUMBER	QTY.	REMARK
1	FRONT BUMPER ASSEMBLY	9AW#-801100-2000	1	
2	FRONT BUMPER	9AW#-801110-2000	1	
3	MOUNTING BRACKET, LH	9AW#-801101-2000	1	
4	MOUNTING BRACKET, RH	9AW#-801102-2000	1	
5	BRACKET, LICENSE PLATE	9AW#-801130-2000	1	
6	PLUG 38	9DS#-801200-6000-20	4	
7	BOLT M8X16	30006-080016870	4	

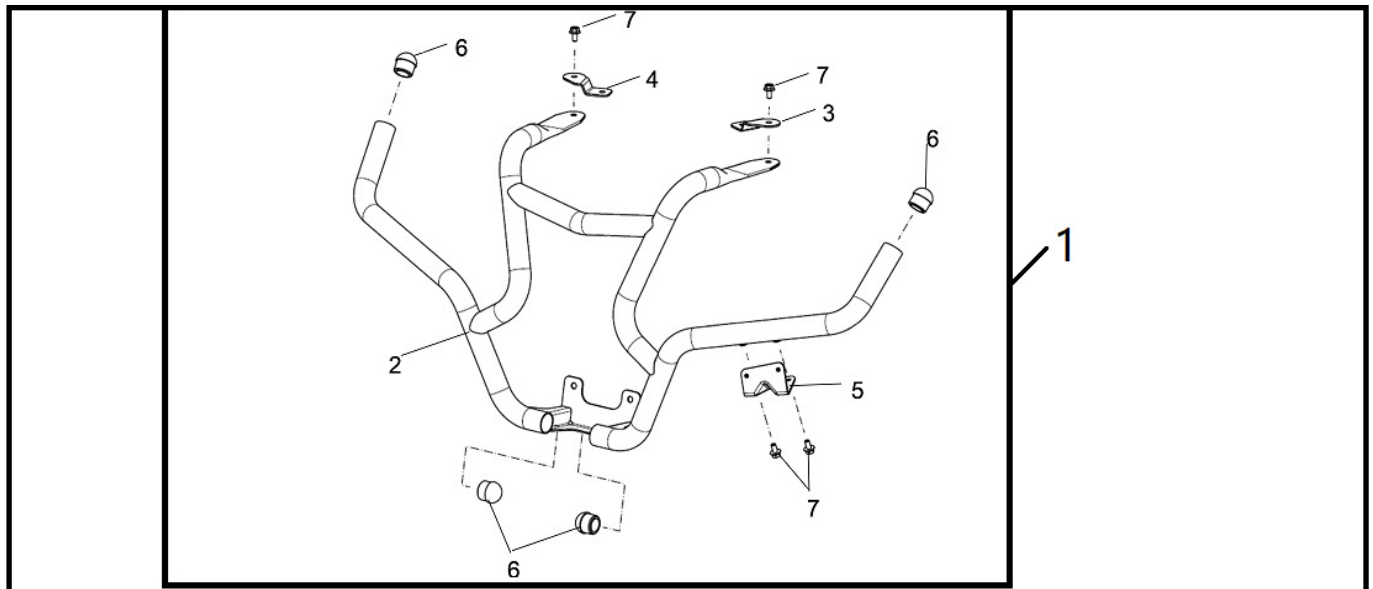

TOOL LIST:

ITEM	DESCRIPTION	QTY.	REMARK
1	13mm SOCKET	1	Recommended tools
2	10mm SOCKET	1	
3	RUBBER HAMMER	1	
4	PROTECTIVE GLOVES	1	

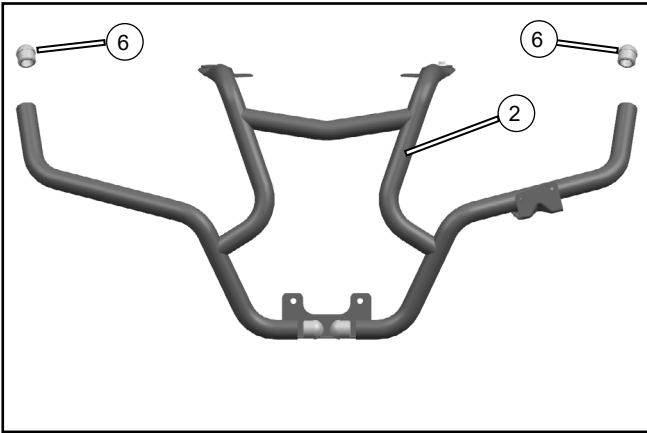
ASSEMBLY and INSTALLATION

// Use a rubber hammer to install the plugs (6) into the front bumper (2).

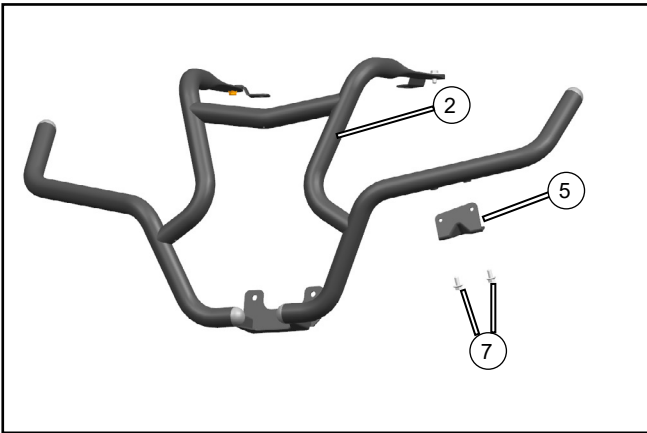

// Install the license plate bracket (5) to the front bumper (2) with bolt (7).

BOLT	M8x16	30006-080016870	8-16N.m
------	-------	-----------------	---------



// Turn the winch quick release knob to the 'FREESPOOL' position and release the winch cable.

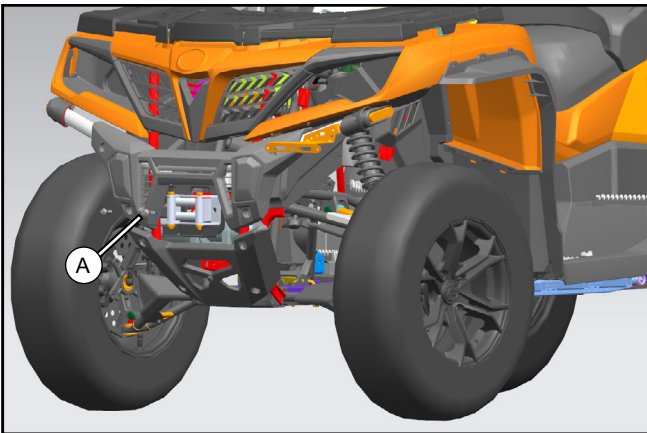

// Remove the winch fairlead bolts (A).

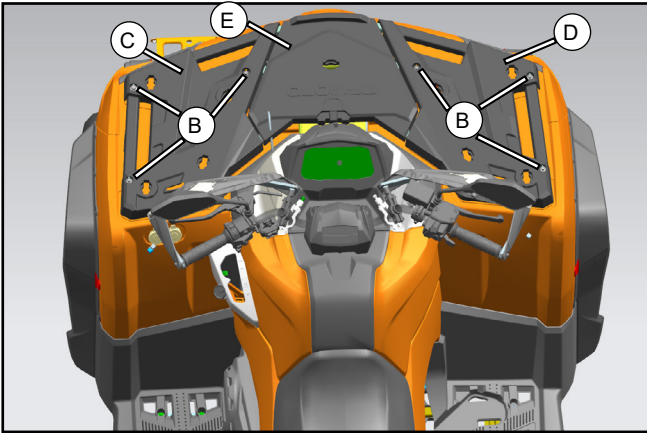
ASSEMBLY and INSTALLATION

// Remove the bolts (B) and take down the left cover (C), center cover (E), right cover (D) in turn.

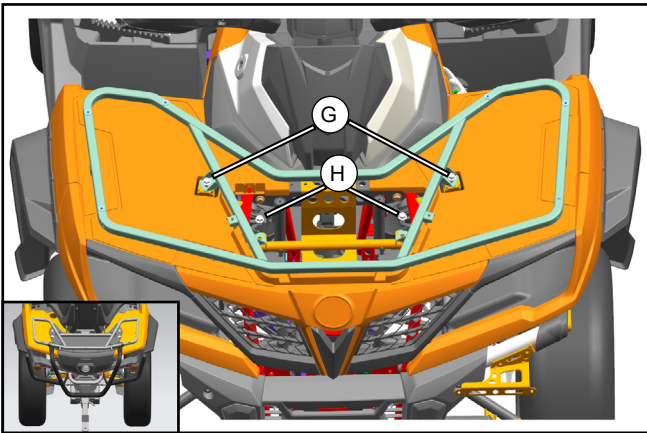

// Remove bolts (H) and loosen bolts (G).

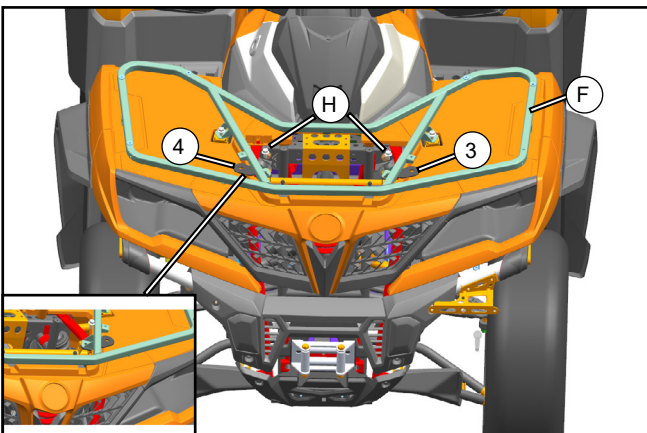

// Lift the front rack assembly (F).
 // Install the left mounting bracket (3) and right mounting bracket (4) to the front rack with bolts (H).

BOLT	M8x16	30006-080016870	8-16N.m
------	-------	-----------------	---------

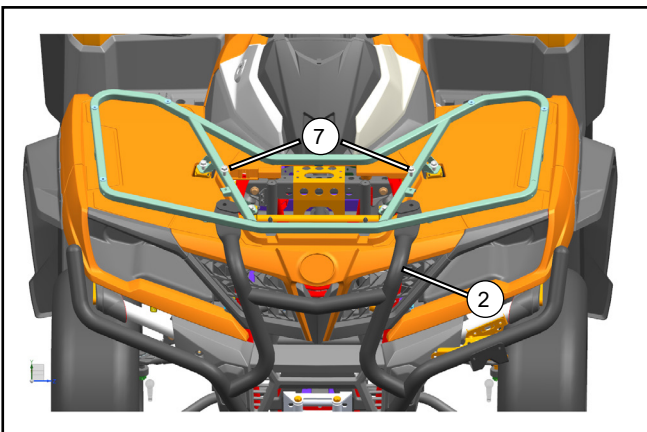

// Align the upper bumper mount (2) to the mounting bracket (3,4) mounting holes, then install the bolts (7).
Do not fully tighten bolts at this time.

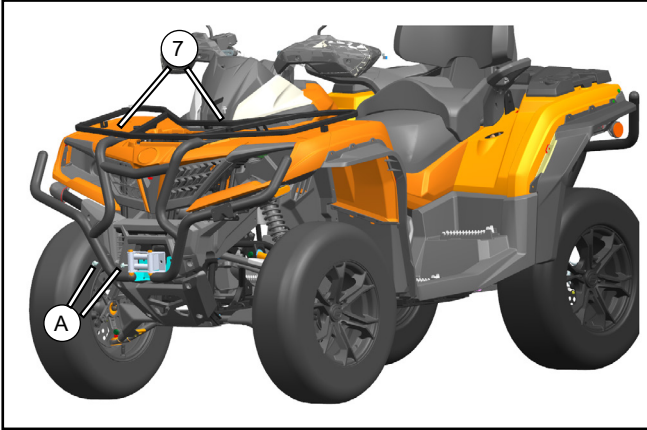
ASSEMBLY and INSTALLATION

- // Align the winch fairlead and lower bumper mount to the mounting holes, then install the previously removed M10x20 bolts (A).
- // Tighten all bolts to the specified torque value.
- // Retract the winch rope.

i NOTE: Winch fairlead is placed on top of the bumper.

BOLT	M10x20	30006-0100020810	16-20N.m
BOLT	M8x16	30006-080016870	8-16N.m

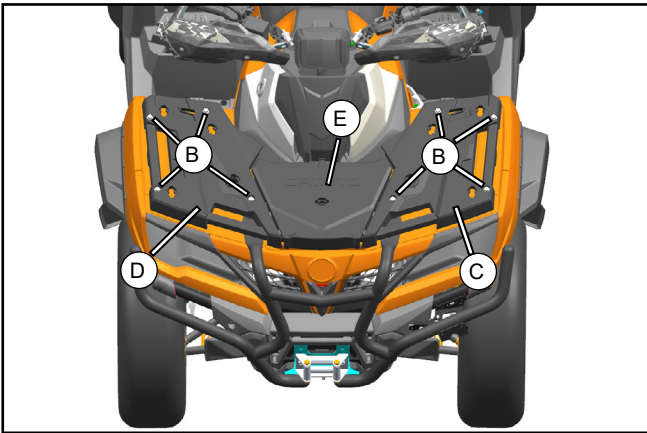

- // Install the left cover (C) and right cover (D) to the front rack with bolts (B).
- // Install the center cover (E).

BOLT	M6x14	8010-000004	6-10N.m
------	-------	-------------	---------