

ACCESSORY SETUP INSTRUCTIONS

SEAT, TALL OR LOW PN: 6AQV-807100-4000 / 6AQV-807200-4000

VALID FOR: CF450SS/450NK

This setup document is based on the tall seat. Assembly of the low seat is similar.

BEFORE YOU BEGIN: Read and understand the instructions before starting any work. Make sure that all parts are ready and that you have all the tools required for assembly.

NOTE: CFMOTO shall not be liable for any damage caused by incorrect assembly. CFMOTO recommends that all original accessories be assembled by an authorized CFMOTO dealer.

Before assembly, park the vehicle on a flat surface and turn off the key switch.

Zhejiang CFMOTO Power Co., Ltd. All rights reserved. Reproduction of this document, even in part, as well as copying of all kinds, is permitted only with the express written permission of the copyright owner.

MEANING OF SYMBOLS



- Indicates information with more details or tips.



- Indicates information of warning or danger.

PART LIST:

ITEM	PART NAME	PART NUMBER	QTY.	DESCRIPTION
1	SEAT, TALL	6AQV-807100-4000	1	For structure reference only.
	SEAT, LOW	6AQV-807200-4000	1	

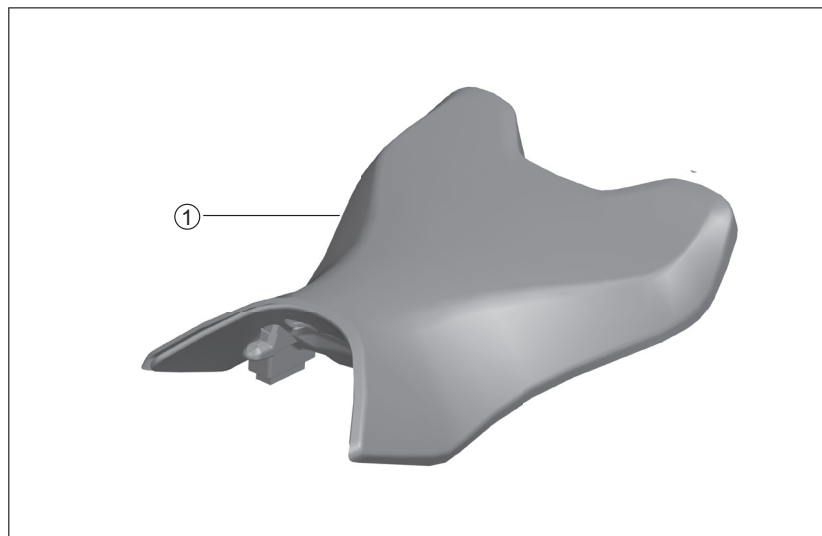

TOOL LIST:

ITEM	DESCRIPTION	REMARK
1	INNER HEX WRENCH s=5	Recommended Tools
2	PROTECTIVE GLOVES	

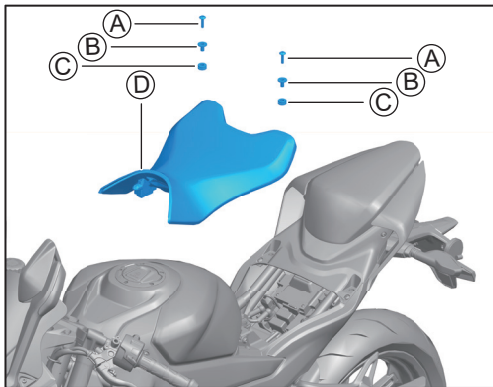
ASSEMBLY and INSTALLATION

- 1** // Unlock and remove the rear seat.
- // Remove the bolts (A) and front seat (D). Then disassemble the bushings (B) and rubber washers (C) from the front seat.

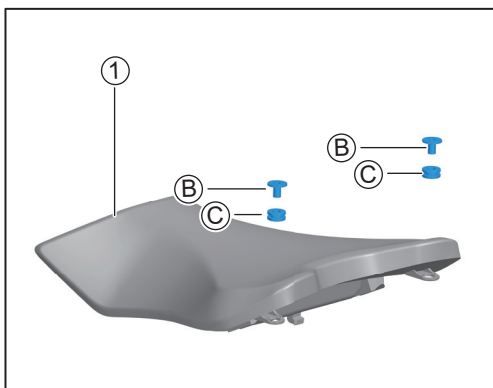

- 2** // Install the original bushings (B) and washers (C) on the new front seat (1) as shown.

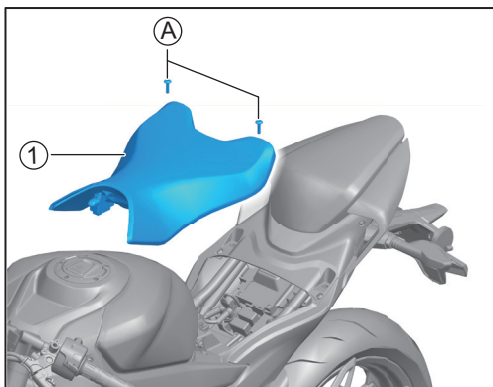

- 3** // Install the new front seat (1) and secure it with the two original bolts (A).
- // Reinstall the rear seat.