

ACCESSORY SETUP INSTRUCTION

FRONT BUMPER ASSEMBLY WITH BRUSH GUARD -- PN 5BY#-801100-1000

VALID FOR: MY2020 ZFORCE 950 & ZFORCE 1000

BEFORE YOU BEGIN: Read and understand the instructions before starting any work. Make sure that all parts are ready and that you have all the tools required for assembly.

NOTE: CFMOTO shall not be liable for any damage caused by incorrect assembly. CFMOTO recommends that all original accessories be assembled by an authorized CFMOTO dealer.

Before assembly, park the vehicle on a flat surface, put the transmission gear into Park (P) and turn off the key switch.

Zhejiang CFMOTO Power Co., Ltd. All rights reserved. Reproduction of this document, even in part, as well as copying of all kinds, is permitted only with the express written permission of the copyright owner.

MEANING OF SYMBOLS

 - Indicates information with more details or tips.

 - Indicates information of warning or danger.

PARTS LIST:

ITEM	PART NAME	PART NUMBER	QTY.	REMARK
1	FRONT BUMPER ASSY	5BY#-801110-1000	1	
2	BRUSH GUARD	5BY#-801103-1000	1	
3	CLAMP 42	5BY#-801220-1000	2	
4	INNER HEX SCREW M10×30	5BY#-801100-1000-21	2	
5	GASKET	5BY#-801102-1000	2	
6	INNER HEX SCREW M6×20	6NQ#-000203-6000	2	
7	INNER HEX SCREW M6×30	5BY#-801104-1000	2	
8	FRONT BUMPER ASSEMBLY WITH BRUSH GUARD	5BY#-801100-1000	1	

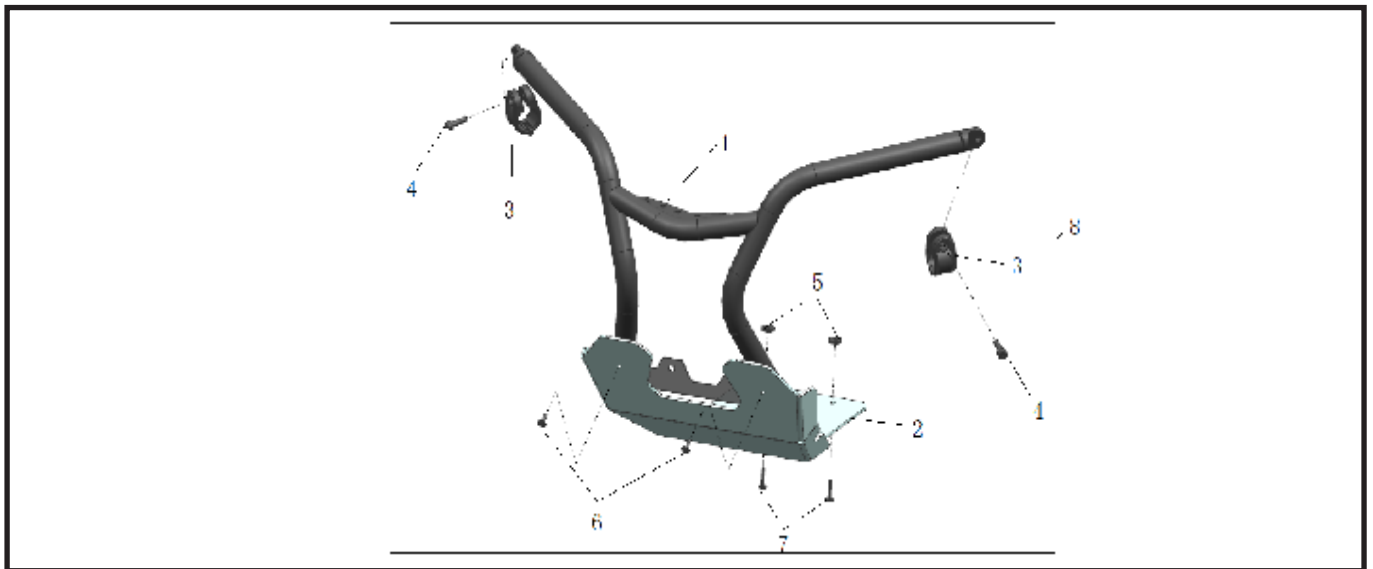

TOOL LIST:

ITEM	DESCRIPTION	QTY.	REMARK
1	5mm HEX BIT SOCKET	1	Recommended tools
2	4mm HEX BIT SOCKET	1	
3	SOCKET 13mm	1	
4	TORQUE WRENCH	1	
5	SOCKET 10mm	1	
6	PROTECTIVE GLOVES	1	
7	RUBBER HAMMER	1	

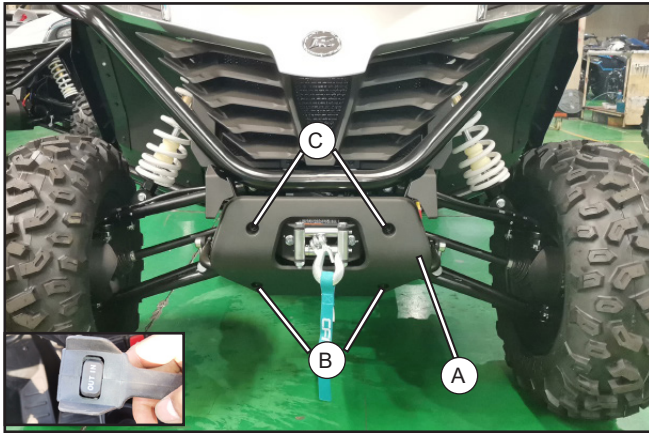

- // Remove bolts (B)(C) and the winch deco guard (A). These parts will not be reused.
- // Turn on the main key switch, then press and hold the winch 'OUT' button to let out the winch rope approximately 30cm.

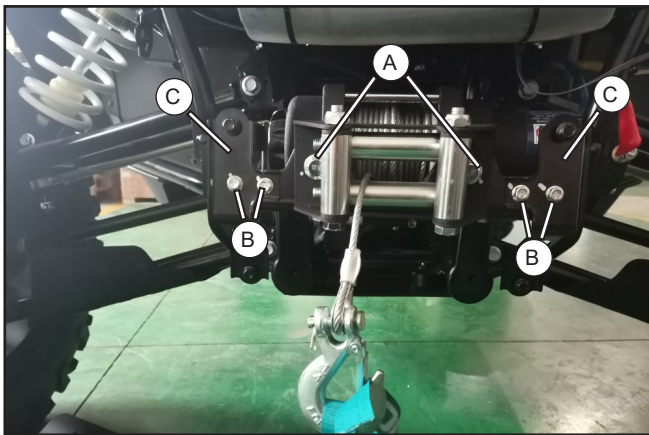

- // Remove bolts (A,B) and mounting brackets (C).

i » Bolts (B) and mounting brackets (C) are not required to install the front bumper.

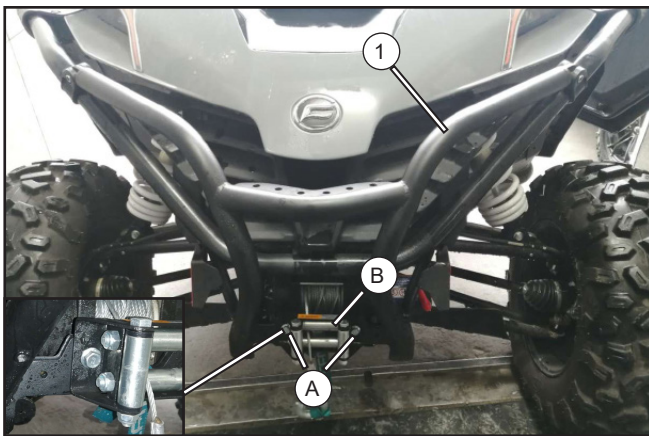

- // Position the bumper assembly (1) behind the cable pulley (B) as shown. Reinstall the cable pulley bolts (A) but do not tighten them at this time.

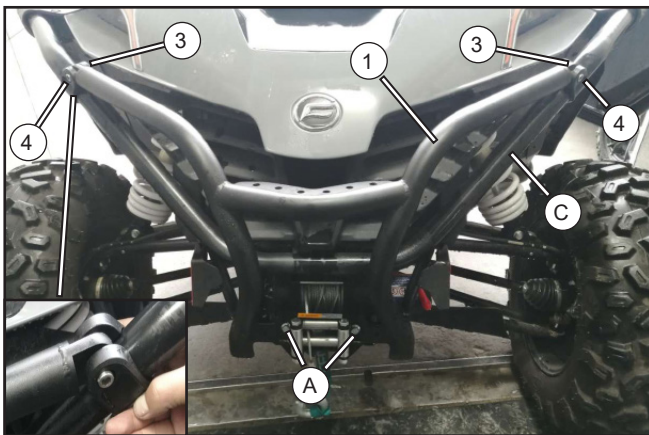

- // Install the clamps (3) around the vehicle front bumper (C), then secure the bumper assembly (1) with inner hex screws (4).
- // Torque the cable pulley bolts (A) and inner hex screws (4) evenly to specification.

i » Ensure that the front bumper assembly (1) is installed in the correct position.
 » Torque the bolts (A) in the previous step evenly to specification.

INNER HEX SCREW	M10×30	5BY#-801100-1000-21	35-45N.m
BOLT (A)	M10×20	30006-102020180	40-50N.m

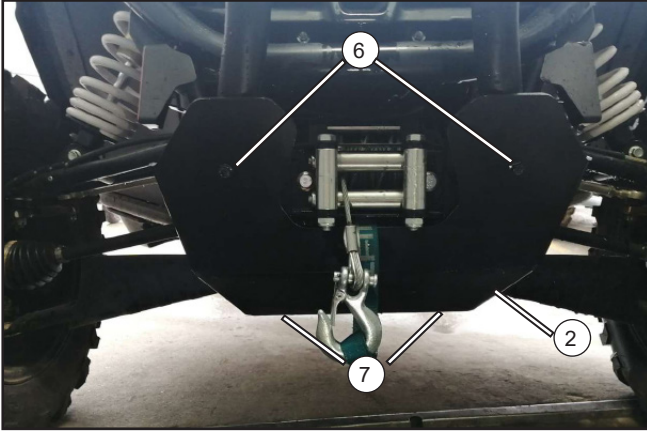

- // Install the brush guard (2) with upper screws (6) and lower screws (7).
- // Torque the screws evenly to specification.
- // Retract the winch rope.

INNER HEX SCREW	M6×20	6NQ#-000203-6000	8-12N.m
INNER HEX SCREW	M6×30	5BY#-801104-1000	8-12N.m